

# Laser Controller

Model No. D2-105 / D2-105-500

Document Revision: 4.2

Document Last Updated on 2019/03/19 18:01

Please read [Limited Warranty](#) and [General Warnings and Cautions](#) prior to operating the D2-105.

[D2-105 web page](#)

## Description:

The laser controller has two temperature controllers capable of sub-mK stability<sup>1)</sup> and a 200 mA or 500 mA precision current source based on the Libbrecht-Hall<sup>2)</sup> circuit. The laser controller is designed for very fast current modulation via the servo input enabling high-speed servo control of the laser's frequency. The current servo input can accommodate input frequencies over 10 MHz and is limited by the 1 kΩ input impedance. Additionally, an RF port is available for higher frequency modulation.



The range of pole settings for the T2 temperature control loop (diode temperature control) for D2-105 Laser Controllers with Serial Number 2675 and higher (Temperature Control Board Serial Number 6987 and higher) have been modified to allow the user to more easily control a low thermal mass laser assembly such as a Photodigm TOSA. Please use the appropriate instructions in the "Tuning the Temperature Controller" section of this manual for your Laser Controller and laser type.



Always power down the D2-105 completely before making connections to the laser. Never connect or disconnect the D2-105 to/from a laser with the D2-105 energized.



Always turn off the power supply, make connections to this device, and then re-energize the power supply. Never connect this device to a power supply that is switched on and supplying power.

As with any diode laser and controller, improper usage can cause irreparable damage to the diode.



If you are considering using an Uninterruptible Power Supply (UPS) to guarantee operation of your Vescent products through a brown out or black out, great care should be taken in choosing the model. Lower cost models tend to produce modified square wave voltage profiles. The high-frequency components of such a voltage profile may interact poorly with the D2-005 (and down-stream active Vescent modules). If you do choose to use a UPS, select a model that will provide a sine wave voltage profile without higher harmonic components to avoid potential damage to your high-value equipment.

## Purchase Includes:

- D2-105 Laser Controller
- D2-007 Laser Controller Breakout Board

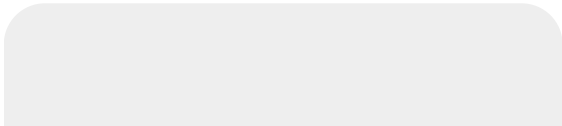

- (See [figure 1.](#))
- VPN00454 Hirose-to-Hirose Laser Temperature Cable (6ft)
  - VPN00463 SMA-to-SMA Laser Current Cable (6ft)
  - VPN00457 Trimpot tweaker (large)
  - VPN00458 Trimpot tweaker (small)
  - VPN00456 DB9 Power Cable (1ft)

Fig. 1:  
D2-007  
Breakout  
board.



## Absolute Maximum Ratings

Note: All modules designed to be operated in laboratory environment

Parameter	Rating
Environmental Temperature	>15°C and <30°C
Environmental Humidity	<60%
Environmental Dew Points	<15°C

## Specifications

	D2-105	D2-105-500	Units
<b>Current Source<sup>3)</sup></b>			
Current range	0-200	0-500	mA
Current noise density	<100	<200	pA /√Hz
RMS Noise (10Hz - 100kHz)	<50	<100	nA
RMS Noise (10Hz - 1MHz)	<100	<150	nA
RMS Noise (10Hz - 10MHz)	<300	<500	nA
Monitor Resolution (Display)	0.1	1	mA
Absolute accuracy	2	2	%
Temperature coefficient	<1	<5	µA/°C
<b>Current Servo Input</b>			
Input impedance	1000	1000	Ω
Bandwidth	>10	>10	MHz
Modulation coefficient	1	1	mA/V
Servo Input Modulation Range	±10	±10	V
RF Input Bandwidth	0.5 - TBD	0.5 - TBD	MHz
<b>Temperature Servo Input</b>			
Input impedance	100	100	kΩ

	D2-105	D2-105-500	Units
Temp modulation coefficient			
Gain = Low	95	95	mK/V
Gain = High	9,000	9,000	mK/V
<b>Temperature Control</b>			
Temperature setpoint range	1-50	1-50	°C
Temperature isolation (T2) <sup>4)</sup>	TBD	TBD	mK/°C
Long term stability (T2)	~1	~1	mK/day
Temperature coefficient <sup>5)</sup> (controller, T2)	TBD	TBD	mK/°C
Max TEC current (voltage)	1 (4)	1 (4)	A (V)
Calibrated to <a href="#">Analog Technologies ATH10KR8 Thermistor</a>		10k	Ω
Analog Technologies ATH10KR8 Beta		3480	K
Analog Technologies ATH10KR8 T <sub>0</sub> <sup>6)</sup>		25	°C

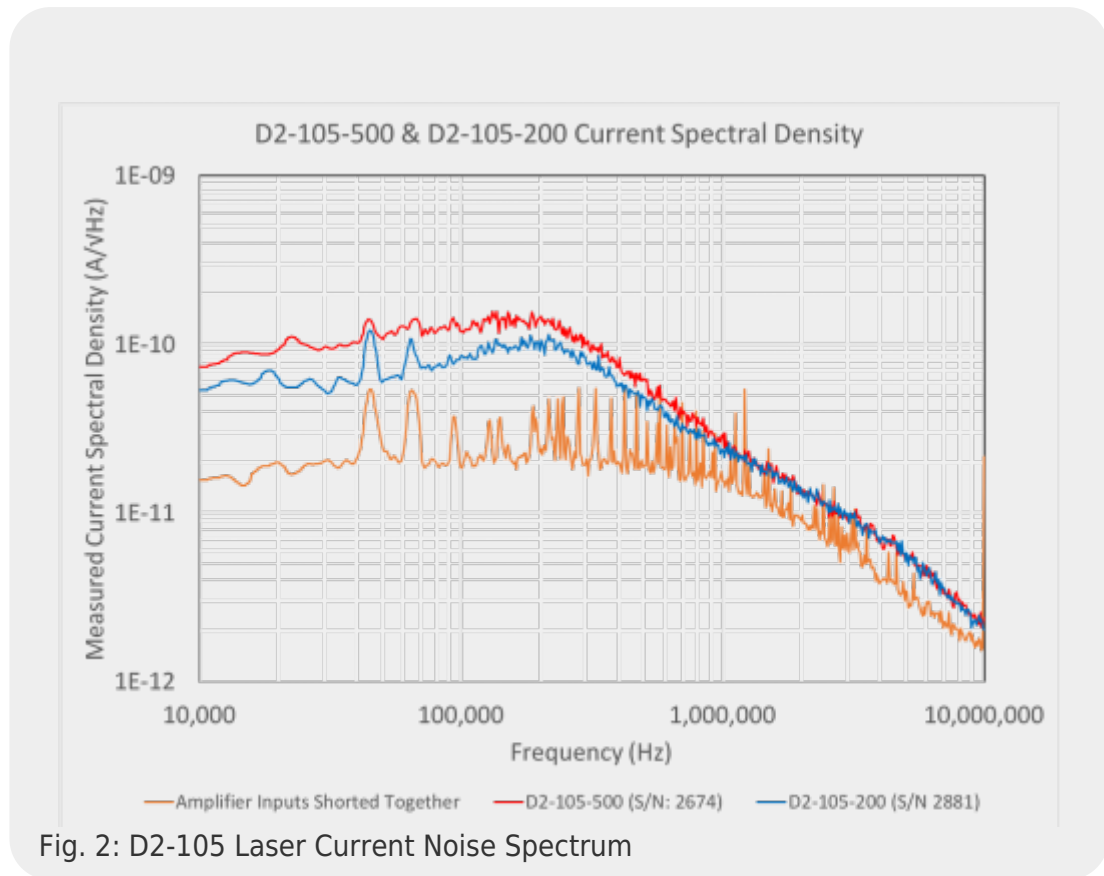

## Inputs, Outputs, and Controls

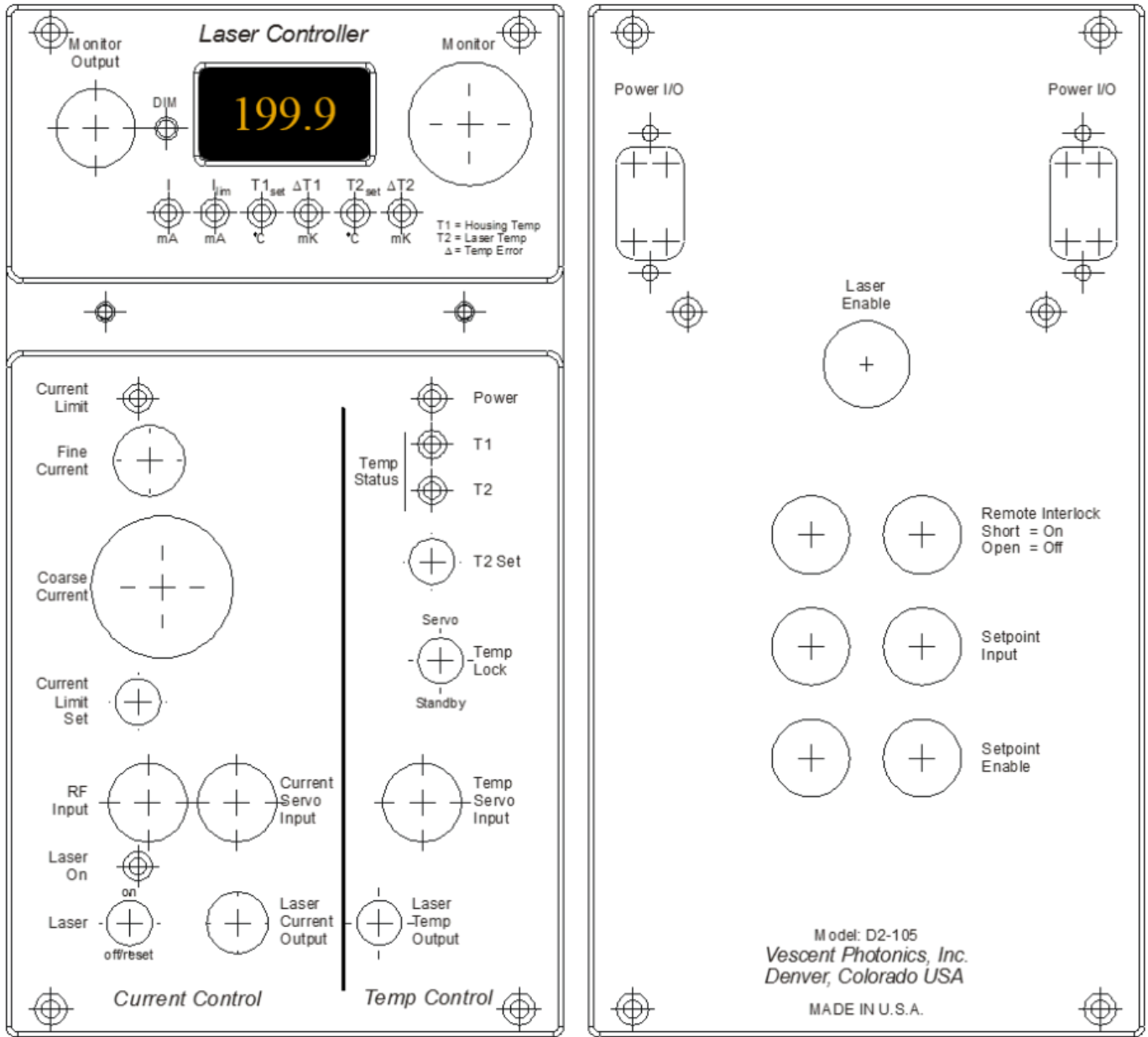

Front and Back Panel of D2-105

### Monitor Section

The monitor section contains a 3½ digit display and an output BNC for monitoring by an oscilloscope or voltmeter. A selector knob controls which of six signals are relayed to the display and BNC. An LED indicator is below the display to show which signal is being displayed and its units.

Name	Symbol	Units	Resolution
Current	I	mA	0.1 mA / 1mA <sup>7)</sup>
Current limit	I <sub>lim</sub>	mA	0.1 mA / 1mA <sup>8)</sup>
Housing Temperature Set	T1 <sub>set</sub>	°C	0.1 °C
Housing Temperature Error	ΔT1	mK	0.1 mK
Laser Temperature Set	T2 <sub>set</sub>	°C	0.1 °C
Laser Temperature Error	ΔT2	mK	0.1 mK

**NOTE:** When the Laser Switch is in the "Off / Reset" position, the laser diode is shorted to ground and

*no current is flowing through the laser diode. However, the Current Monitor will read up to 30 mA of current flowing through the short. This is normal. When the switch is in the "ON" position, the current monitor accurately measures the current flowing through the laser diode.*

The BNC monitor outputs a voltage corresponding to the monitor selection. When monitoring Current or Current limit, the output is 1V = 1 A and will include the current modulation/servo signal from the Servo Input connector. When monitoring a Temperature Setpoint, the output is 1mV = 1°C. When monitoring a Temperature Error, the output is 1V = 1°C.

## **Current Control**

### **Current Lim (LED)**

The current limit indicator lights when the current limit circuit is activated. If the user attempts to set the current over the current limit setpoint the circuit shunts the excess current through a transistor to ground

### **Fine Current (knob)**

The fine current adjusts the diode injection current by ½-1 % of the coarse control setting. Use this control for fine positioning of the laser frequency prior to locking.

### **Course Current (Scale Dial)**

The course current control sets the laser diode injection current between 0 and 200 mA (0 and 500 mA for 500 mA version). To set the current, switch the selector knob in the monitor section so that the current LED (*I*) is lit. Then adjust the course current to the desired setting.

### **Current Limit Set (Trimpot)**

The current limit set is a front panel trimpot adjustment. Set the selector knob to the  $I_{lim}$  position and adjust the trimpot to the desired value. The Current Limit should be set below the maximum current for the laser diode.

### **RF Input (BNC)**

The RF input is ac coupled to the laser diode through a 10 nF capacitor. Over ~3 MHz the impedance of this input will approach the ac impedance of the laser diode of ~5 Ω. This input is normally connected to the RF output from the Laser Servo module, which applies FM sidebands at 4 MHz to the laser output.

*Note: a large voltage transient to this input could possibly cause damage to the laser diode. If you are connecting other equipment to this input do not exceed 0.25 Vrms from a 50 Ω source or 1 mW of power.*

### **Current Servo Input (BNC)**

The current servo input adds or subtracts current though 1 k Ω connected to the laser diode giving a modulation coefficient of 1 mA/V. A bias circuit sets the voltage of the current servo input to zero volts. (Normally, a connection to the laser diode would place this voltage at ~ 2V or equal to the forward diode drop.) Therefore, leaving the input open or grounded does not alter the current to the laser diode.

The bandwidth of the current servo input is >10 MHz.

### Laser On (LED indicator)

Turns ON 5 seconds before laser light turns on. If light is on, laser is on (or will be in <5secs).

### Laser ON-Off/Reset (switch)

When the switch is in the Off/Reset position, the laser diode is turned off and the laser is shorted to ground. When flipped into the On position, the Laser ON (LED indicator) will turn on and 5s later, the laser will turn on. If the laser diode is turned off from the laser enable or remote interlock, this switch must be placed into the Off/Reset position and then into the ON position to turn the laser back on.

Neither the laser nor the Laser ON (LED indicator) will not turn on if any of the following conditions are true:

1. The remote interlock is not engaged
2. The key interlock is not engaged
3. The laser diode is shorted
4. The COARSE CURRENT knob is turned all the way down



If the LED indicator does not turn on when the Laser ON-OFF/Reset switch is flipped up, make sure both interlocks are engaged and that the COARSE CURRENT knob is turned up at least half a turn. If the current is set to 0 mA when you engage the Laser ON switch, the system detects an open circuit (no current flowing) and indicates an error. Due to the "soft start" circuitry employed in the current source, you may safely leave the current at its operating setpoint when engaging and disengaging the Laser ON switch.

If the LED indicator turns on for ~5 seconds and then turns off, check your laser diode connection to see if it is open (or if the diode is backwards).

### Laser Out (SMA)



Always power down the D2-105 completely before making connections to the laser. Never connect or disconnect the D2-105 to/from a laser with the D2-105 energized.

Always turn off the power supply, make connections to this device, and then re-energize the power supply. Never connect this device to a power supply that is switched on and supplying power.

As with any diode laser and controller, improper usage can cause irreparable damage to the diode.

The D2-105 Laser Controller is designed for a grounded cathode only. If the anode of your laser is connected to the laser housing, the housing must be electrically insulated



from ground.

The laser current is output through an SMA connector and returns through the cable shielding to ground.

## Temperature Control

### Power (LED indicator)

All electronic modules have a blue LED power indicator on the top right side of the front panel control section. The LED requires +15V and 5V in order to light.

### Temp Status (dual LED indicators)

The temperature status LED indicators turn red whenever the temperature servo loop has been disengaged. The temperature servo loop will disengage when the temperature is below  $-1^{\circ}\text{C}$ , above  $50^{\circ}\text{C}$ , or the thermistor is shorted or open. Additionally, when the TEMP LOCK is in standby mode, the servo loop is off and the LED's will be red.

The temperature status LED indicators will turn green when the temperature is within a narrow temperature window of the setpoint. The window is typically set to a 100mK for stage 2 and 500mK for stage 1 and can be monitored via T4 on the side-panel.

### T2 Set (Trimpot)

The temperature of the laser diode (T2) is set with a front panel trimpot. When a D2-100 laser is purchased with the controller, T2 is factory set to put the laser at the requested wavelength, typically resonant with hyperfine transitions, and should not need trimming. However, as the diode ages the user might need to adjust this value. Set the display selector knob to read  $T2_{\text{set}}$  and set to the desired value. Note: Before attempting to set the set point temperature, you must connect a thermal plant to the D2-105. If you do not have a plant attached to the temperature loop, the set point range will appear to be limited to less than  $\sim 12^{\circ}\text{C}$ .

T1 is also set at the factory and should not require further adjustment. However, the T1 trimpot can be accessed by removing the right panel from the enclosure. Note: Before attempting to set the set point temperature, you must connect a thermal plant to the D2-105. If you do not have a plant attached to the temperature loop, the set point range will appear to be limited to less than  $\sim 12^{\circ}\text{C}$ .

### Temp Lock (Dual position switch)

The temperature servo can be placed into standby mode if desired. In this mode no current is supplied to the TEC elements.

### Temp Servo Input (BNC)

The temperature servo input is summed to the T2 temperature set point signal and can be used to make electronic perturbations to the laser diode temperature. The Temp Servo Input, has two settings: "Low" and "High" gain. The default settings is "Low" but can be changed by a switch accessible on the right side panel.

When the gain is set to "LOW", the slope for changing the set point is  $\sim 95 \text{ mK/V}$ .



When the gain is set to “HIGH”, turn the set point to the lowest desired temperature. Apply a voltage between -10V and 10V to TEMP SERVO INPUT to adjust the set point temperature. With this configuration, you can sweep the set point all the way from the low-temperature limit (-1°C) to the high-temperature limit (58°C). *NOTE that the Vescent Photonics Lasers should not be operated above 50°C.* The slope for changing the set point is ~9 K/V.

The “Low” mode is designed for slow temperature feedback for long-term (days) stability of the locked laser. Normally the Temp Servo Input is used to drive the dc value from the Current Servo Output on the Laser Servo to zero over long time scales. In other words, temperature tuning is used to remove large, slow variations in the laser frequency. To accomplish this, connect the Temp Servo Output from the Laser Servo module to the Temp Servo Input of the Laser Controller (with TEMP SERVO INPUT Gain is set to “Low”). This connection is only important if the user is trying to maintain a laser lock continuously over many days or even weeks. Without feedback to Temp Servo In the Laser Servo can eventually run out of range.

### Laser Temp Output (8-pin connector)

An 8-pin Hirose connector (see [table 2](#) for identity of connectors) carries the signals for the temperature control of the Laser module. The wiring diagrams are shown in the table below, where 1 (2) refer to stage 1 (2) temperature control, which stabilizes the Laser Housing (Laser Diode). Rth and Rth\_Rtn are the two ends of a 10 kΩ [Analog Technologies ATH10KR8 Thermistor](#).

Pin	Signal
1	TEC1+
2	TEC1-
3	Rth1
4	Rth1-RTN
5	TEC2+
6	TEC2-
7	Rth2
8	Rth2-RTN

Tab. 1: TEC connector pin out

Connector Location	Connector (Hirose Part Number)
D2-105 Bulkhead	<a href="#">HR25-7TR-8SA</a>
Cable Connection to D2-105	<a href="#">HR25-7TP-8P</a>
Cable Connection to D2-100	<a href="#">HR25-7TP-8S</a>
D2-100 Bulkhead	<a href="#">HR25-7TR-8PA</a>

Tab. 2: Connectors used in Temperature Control Cabling

## Back panel I/O

### Power I/O (9-pin D-sub)



When making power connections to and from the D2-105, always turn off the power supply, make connections to the device, and then re-energize the power supply. Never connect this device to a power supply that is switched on and supplying power.



If you are considering using an Uninterruptible Power Supply (UPS) to guarantee operation of your Vescent products through a brown out or black out, great care should be taken in choosing the model. Lower cost models tend to produce modified square wave voltage profiles. The high-frequency components of such a voltage profile may interact poorly with the D2-005 (and down-stream active Vescent modules). If you do choose to use a UPS, select a model that will provide a sine wave voltage profile without higher harmonic components to avoid potential damage to your high-value equipment.

The power to each electronics module is through a 9-pin D-sub connector through a power bridge unit. The unit can also be powered through any serial cable with 9-pin D-sub connectors, which is convenient when the unit must be taken out of line for access to the side panels. The pin outs are shown in the following figure:

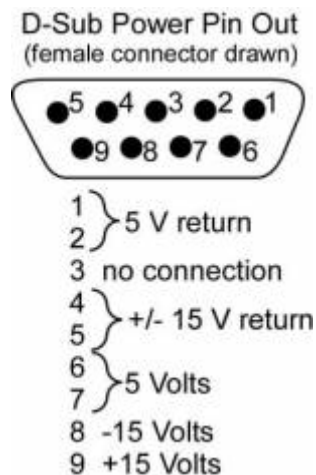

### Laser Enable

This key-switch is required to be in the enable position for the laser to turn on. Normally, the key is left in the enable position.

### Remote Interlock

The remote interlock can be used to disable the laser diode output via an interlock control. When this input is shorted the laser diode output is ON. When the input is open the diode output is OFF. If not

used, leave a shorting cap over this BNC. Once the interlock has been tripped, the laser will stay off until it is manually reset with the front panel switch.

### Setpoint In

SETPOINT IN is an analog input. When the SETPOINT ENABLE is LOW (0 V) the SETPOINT IN voltage value sets the injection current instead of the front panel dial. Zero volts sets zero current and 6 V sets the maximum value of 200 mA (500 mA for 500 mA version).

This input is rolled off at 14 Hz, which is not much higher frequency than the front panel dial, which rolls off at 8 Hz, with a second pole at 4 Hz. Therefore, noise can enter the circuit at this point and this input should be used with caution. It is primarily intended for sweeping the current in order to measure PI curves and threshold values of laser diodes. We do not recommend using this input for computer control of the injection current.

### Setpoint Enable

SETPOINT ENABLE is a TTL input. 5 V puts the front panel dial in control of the injection current and 0 V gives control to SETPOINT IN.

When disconnected, the SETPOINT ENABLE is at 5 V.

## Turning on the Laser Diode

In compliance with FDA requirements for a Class 3B laser, the Laser Controller has two safety interlocks. If either interlock is tripped, the laser will turn off and stay off until the interlocks are reset AND the laser switch is switched from the "off / reset" position to the "on" position. Additionally, if the Laser Controller loses power, the laser diode will remain off when power is restored.

To turn on the laser diode, follow these instructions:

- Flip the Laser switch into "off/reset" position
- Insert the key into the keyhole and rotate the key 90 degrees (keyhole located on back panel)
- Place grounding BNC terminator on "Remote Interlock" BNC (located on back panel)
- Flip the Laser switch into the "on" position. The green light above the switch should turn on and after a 5 second delay, the laser will turn on.

## Tuning the Temperature Controller



The range of pole settings for the T2 temperature control loop (diode temperature control) for D2-105 Laser Controllers with Serial Number 2675 and higher (Temperature Control Board Serial Number 6987 and higher) have been modified to allow the user to more easily control a low thermal mass laser assembly such as a Photodigm TOSA. Please use the appropriate instructions below for your Laser Controller.

If you purchased the Laser Controller with a Laser Module, then the Laser Controller is properly tuned

for the Laser Module's thermal load and you can skip this section. This section will describe the basic theory about tuning the temperature servo response and provide step-by-step instructions for tuning the servo response to your thermal load.

To get good temperature stability, the temperature servo response needs to be tuned to match the thermal load. Access to tuning the temperature response is provided on the right side panel of the Laser Controller and requires removing that side panel to access the controls. The Laser Controller provides two independent temperature controllers that are nominally identical for models with S/N 2674 and below or PCBs with S/N 6986 or below and differ by a factor of 10 in their time constants for models with S/N 2675 and above or PCBs with S/N 6987 or above. In either case, stage 2 has front panel adjustment of the temperature set-point, while the stage 1 temperature set-point is a side-panel adjustment. Additionally, the front panel TEMP SERVO INPUT adjusts the stage 2 set-point while stage 1 does not have an equivalent function. Stage 2 is accessed in the middle of the side-panel, while stage 1 is near the back of the side panel. Typically, stage 2 is used to control the laser temperature and stage 1 is used to control the temperature surrounding stage 2. In this way temperature gradients between the laser diode and the thermistor measuring the laser temperature are stabilized and temperature changes caused by room temperature drift are greatly reduced.

### Laser Controller Serial Numbers above 2675, inclusive; Temperature Control Board Serial Numbers above 6987, inclusive

To reset the temperature loop parameters to the factory settings for a D2-100-DBR Laser:

1. Set the dip switches to the configuration shown in [table 3](#) and [table 4](#) and [figure 3](#).
2. Measure the resistance across GND5 and probe point GAIN1. Set this resistance to between 3.0 k $\Omega$  and 3.2 k $\Omega$  by adjusting trimpot PROPGAIN1.
3. Measure the resistance across GND5 and probe point GAIN2. Set this resistance to between 1.2 k $\Omega$  and 1.4 k $\Omega$  by adjusting trimpot PROPGAIN2.

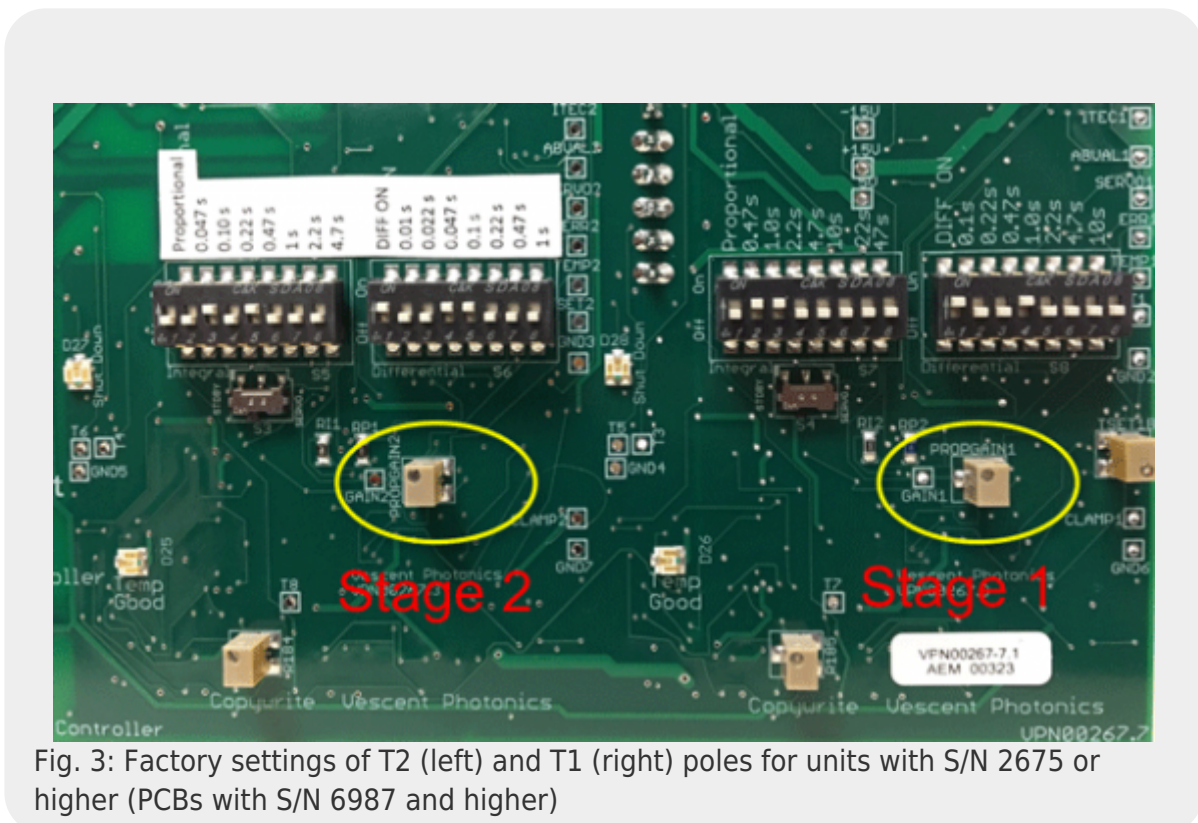

Fig. 3: Factory settings of T2 (left) and T1 (right) poles for units with S/N 2675 or higher (PCBs with S/N 6987 and higher)

<b>T2</b>	<b>Prop. On</b>	<b>0.047 s</b>	<b>0.1 s</b>	<b>0.22 s</b>	<b>0.47 s</b>	<b>1.0 s</b>	<b>2.2 s</b>	<b>4.7 s</b>
<b>On</b>			X		X			
<b>Off</b>	X	X		X		X	X	X
<b>T2</b>	<b>Diff. On</b>	<b>0.01 s</b>	<b>0.022 s</b>	<b>0.047 s</b>	<b>0.1 s</b>	<b>0.22 s</b>	<b>0.47 s</b>	<b>1.0 s</b>
<b>On</b>	X			X	X			
<b>Off</b>		X	X			X	X	X

Tab. 3: Factory settings of T2 Proportional poles (first DIP switch in figure) and T2 Differential poles (second DIP switch in figure) for units with S/N 2675 or higher (PCBs with S/N 6987 and higher)

<b>T1</b>	<b>Prop. On</b>	<b>0.47 s</b>	<b>1.0 s</b>	<b>2.2 s</b>	<b>4.7 s</b>	<b>10 s</b>	<b>22 s</b>	<b>47 s</b>
<b>On</b>				X				
<b>Off</b>	X	X	X		X	X	X	X
<b>T1</b>	<b>Diff. On</b>	<b>0.1 s</b>	<b>0.22 s</b>	<b>0.47 s</b>	<b>1.0 s</b>	<b>2.2 s</b>	<b>4.7 s</b>	<b>10 s</b>
<b>On</b>	X	X	X	X				
<b>Off</b>					X	X	X	X

Tab. 4: Factory settings of T1 Proportional poles (third DIP switch in figure) and T1 Differential poles (fourth DIP switch in figure) for units with S/N 2675 or higher (PCBs with S/N 6987 and higher)

To reset the temperature loop parameters to the approximate settings for a Photodigm TOSA DBR Laser:

1. The T1 loop is not used as the TOSA only has one TEC.
2. Set the T2 dip switches to the configuration shown in [table 5](#).
3. Measure the resistance across GND5 and probe point GAIN2. Set this resistance to between 1.01 kΩ and 1.03 kΩ by adjusting trimpot PROPGAIN2.

<b>T2</b>	<b>Prop. On</b>	<b>0.047 s</b>	<b>0.1 s</b>	<b>0.22 s</b>	<b>0.47 s</b>	<b>1.0 s</b>	<b>2.2 s</b>	<b>4.7 s</b>
<b>On</b>			X					
<b>Off</b>	X	X		X	X	X	X	X
<b>T2</b>	<b>Diff. On</b>	<b>0.01 s</b>	<b>0.022 s</b>	<b>0.047 s</b>	<b>0.1 s</b>	<b>0.22 s</b>	<b>0.47 s</b>	<b>1.0 s</b>
<b>On</b>	X					X		
<b>Off</b>		X	X	X	X		X	X

Tab. 5: Factory settings of T2 Proportional poles (first DIP switch in figure) and T2 Differential poles (second DIP switch in figure) for units with S/N 2675 or higher (PCBs with S/N 6987 and higher) when using a Photodigm TOSA DBR Laser



### Laser Controller Serial Numbers 2674 and below; Temperature Control Board Serial Numbers below 6987

To reset the temperature loop parameters to the factory settings:

1. Set the dip switches to the configuration shown in [table 6](#) and [table 7](#) and [figure 4](#).
2. Measure the resistance at probe points GAIN1 and GAIN2. Set GAIN1 and GAIN2 between 715 Ω and 785 Ω by adjusting trimpot PROPGAIN1 and PROPGAIN2, respectively.

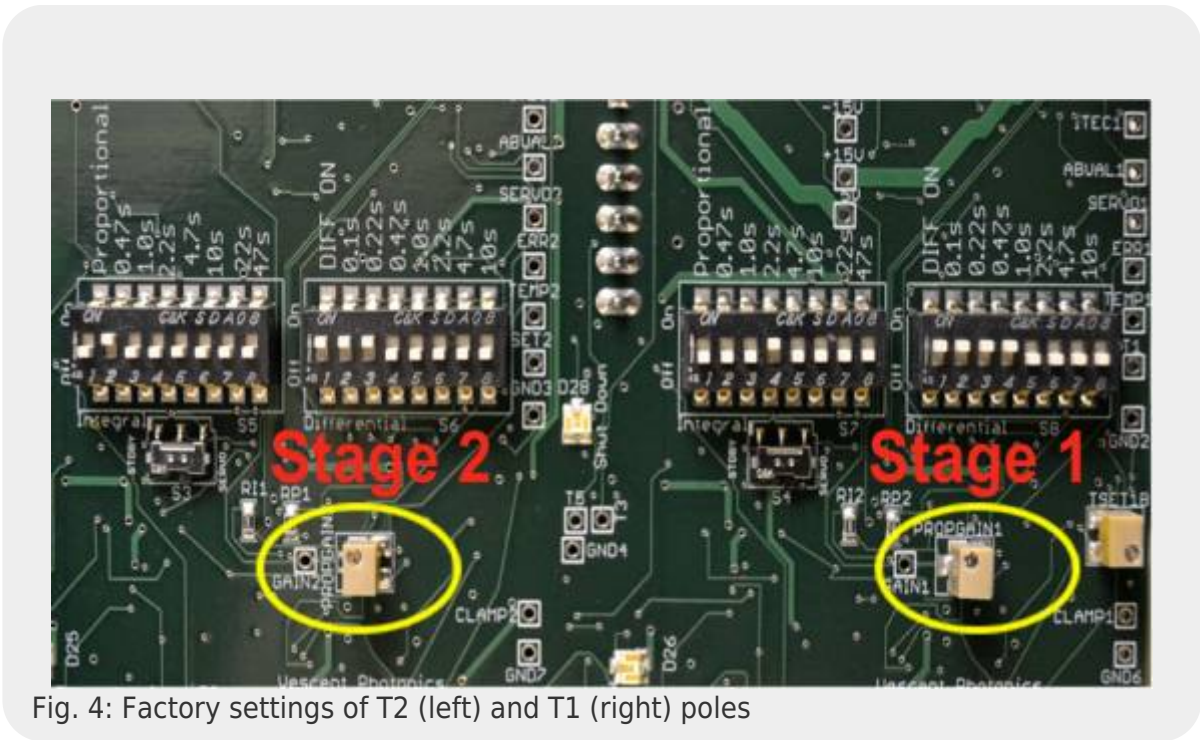

Fig. 4: Factory settings of T2 (left) and T1 (right) poles

<b>T2</b>	<b>Prop. On</b>	<b>0.47 s</b>	<b>1.0 s</b>	<b>2.2 s</b>	<b>4.7 s</b>	<b>10 s</b>	<b>22 s</b>	<b>47 s</b>
<b>On</b>		X						
<b>Off</b>	X		X	X	X	X	X	X
<b>T2</b>	<b>Diff. On</b>	<b>0.1 s</b>	<b>0.22 s</b>	<b>0.47 s</b>	<b>1.0 s</b>	<b>2.2 s</b>	<b>4.7 s</b>	<b>10 s</b>
<b>On</b>	X	X	X					
<b>Off</b>				X	X	X	X	X

Tab. 6: Factory settings of T2 Proportional poles (first DIP switch in figure) and T2 Differential poles (second DIP switch in figure)

<b>T1</b>	<b>Prop. On</b>	<b>0.47 s</b>	<b>1.0 s</b>	<b>2.2 s</b>	<b>4.7 s</b>	<b>10 s</b>	<b>22 s</b>	<b>47 s</b>
<b>On</b>				X				
<b>Off</b>	X	X	X		X	X	X	X
<b>T1</b>	<b>Diff. On</b>	<b>0.1 s</b>	<b>0.22 s</b>	<b>0.47 s</b>	<b>1.0 s</b>	<b>2.2 s</b>	<b>4.7 s</b>	<b>10 s</b>
<b>On</b>	X	X	X	X				

Off					X	X	X	X
-----	--	--	--	--	---	---	---	---

Tab. 7: Factory settings of T1 Proportional poles (third DIP switch in figure) and T1 Differential poles (fourth DIP switch in figure)

To get good temperature stability, the temperature servo response needs to be tuned to match the thermal load. Access to tuning the temperature response is provided on the right side panel of the Laser Controller and requires removing that side panel to access the controls. The Laser Controller provides two independent temperature controllers that are nominally identical. However, stage 2 has front panel adjustment of the temperature set-point, while the stage 1 temperature set-point is a side-panel adjustment. Additionally, the front panel TEMP SERVO INPUT adjusts the stage 2 set-point while stage 1 does not have an equivalent function. Stage 2 is accessed in the middle of the side-panel, while stage 1 is near the back of the side panel. Typically, stage 2 is used to control the laser temperature and stage 1 is used to control the temperature surrounding stage 2. In this way temperature gradients between the laser diode and the thermistor measuring the laser temperature are stabilized and temperature changes caused by room temperature drift are greatly reduced.

### Transfer Function and Poles

Each stage of temperature control has a transfer function shown below:

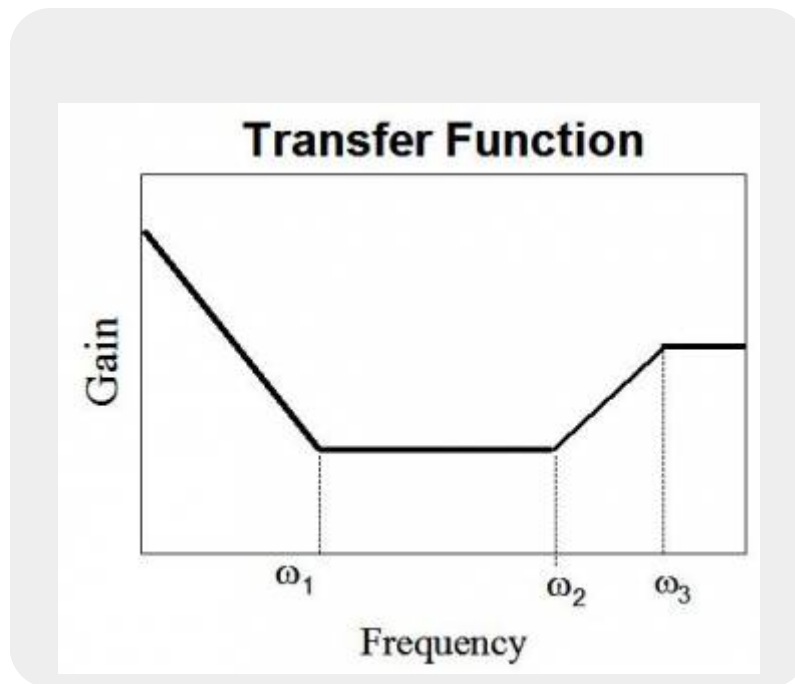

The two poles ( $\omega_1$  and  $\omega_2$ ) and the overall gain can be adjusted using trimpots and click-switches on the side panel. The first pole ( $\omega_1$ ) is the Proportional-Integrator (PI) pole, or the frequency where the gain switches from being an integrator to proportional. The second pole ( $\omega_2$ ) is the Differential (D) pole, or the frequency where the gain becomes differential. The final (non-adjustable) pole ( $\omega_3$ ) is where the differential gain ends and the gain becomes proportional again and is internally set to twenty-five times  $\omega_2$ .

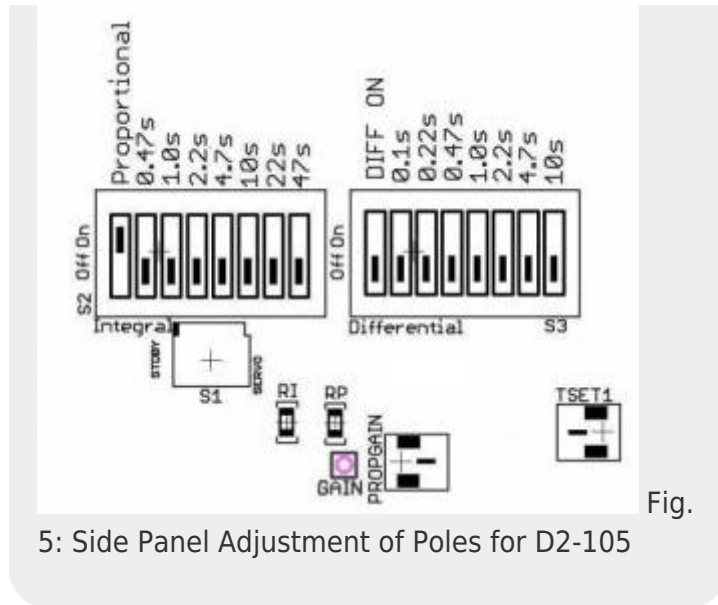

Fig.

5: Side Panel Adjustment of Poles for D2-105

## User Control of the Poles and Gain

If you remove the right side panel on the Laser Controller, for each stage of temperature control, you will see the panel shown in figure 5. The set of click switches labeled “Integral” controls the PI ( $\omega_1$ ) pole. Clicking the first switch, labeled “proportional,” into the on position removes the integral gain (but not the differential gain). If the “proportional” switch is in the off position (integral gain is now on), then the sum of the times for all switches in the on position gives the RC time-constant for the PI pole. For example, if the 2<sup>nd</sup> (0.47s) switch and the 4<sup>th</sup> (2.2s) switch are in the on position (and the rest off), then the time constant is 2.7s and  $\omega_1 = 1/2.7s = 0.37$  Hz.

Similarly, the switches labeled “Differential” control the D ( $\omega_2$ ) pole. If the first switch, labeled “Diff On” is in the off position, then there is no differential pole. If the “Diff On” switch is on, then the D pole has an RC time-constant given by the sum of the times of all the switches in the on position, same as with the Integral bank of switches.

The “PROPGAIN” trimpot tunes the overall gain of the system and is adjustable by a factor of 200.

Additionally, the TSET1 trimpot is used to adjust the set-point temperature for stage 1 (stage 2 is controlled on the front panel).

The “STBY / SERVO” switch can disable temperature controller for either stage by placing the switch into STBY (standby) mode. In this mode, a red light will be shown on the front-panel to show that the stage has been disabled.

## Tuning the Thermal Loop

Although there are numerous methods for tuning the loop parameters, these instructions will use the Ziegler-Nichols tuning method.

For nested stages (one stage is inside a housing whose temperature is controlled by another stage), we recommend tuning the outside stage first with the inside stage turned off. Then tune the inside stage while the outside stage is turned on. For the stage directly controlling the laser temperature, we recommend running the tuning procedure while the laser is on. For each stage, follow the steps below to tune the plants according to the Ziegler-Nichols tuning method:



1. Connect thermal load to Laser Controller.
2. Place Loop in proportional-only mode: Switch labeled "Proportional" is on, switch labeled "Diff On" is off.
3. Turn the gain all the way down (trimpot labeled "PROPGAIN" all the way CCW).
4. Turn on temperature loop.
5. Adjust set-point to approximately desired temperature.
6. Turn up the gain. Keep increasing the gain until the temperature error (front panel BNC) just start to oscillate or ring with very little damping. If oscillation too large, reduce gain. Measure the period of oscillation.
7. Turn off the Laser Controller. Measure resistance between "GAIN" testpoint and "GND" testpoint. Turn down the "PROPGAIN" until this resistance reads 1.7 times less than its original value (i.e. from 500Ω to 295Ω).
8. Take the measured oscillation period in step 6 and divide by two. Set the Integrator time constant to this value. For instance, if you measured a period of oscillation of 14 seconds, turn on the 4<sup>th</sup> (2.2s) and 5<sup>th</sup> (4.7s) switches in the integrator bank, to get a time constant of 6.9s.
9. Turn off the "proportional" switch.
10. **[Old models only]** Turn the "DiffGain" trimpot all the way CW. ("DiffGain" not adjustable on newer models.)
11. Set the "Differential" switches to the same position as the "integral" one. This works out to setting a D time constant roughly equal to 1/8 of the period of oscillation. For the previous example, set the 4<sup>th</sup> (0.47s) and 5<sup>th</sup> (1.0s) switches on to get a time constant of 1.5s.
12. Turn on the "Diff On" switch.
13. Your thermal loop is now tuned. The "proportional" switch will remain in the off position for most plants. Power up the Laser Controller and wait for the temperature to stabilize. Change the setpoint and observe the temperature error and verify that the oscillations are damped and the temperature stabilizes. You may be able to get better performance by tweaking the poles and gain.

*NOTE: Depending on the thermal design, nested temperature loops can fight each other, causing oscillations and instability. If you observe this, you will need to reduce the gain and/or increase the time-constants on the slower stage.*

## Tuning Temperature Loop for Photodigm Mercury Lasers

If you are using the D2-105 laser controller to drive a Photodigm Mercury laser in a TOSA package, the following may be helpful as a starting point for setting the thermal control loop parameters.<sup>9)</sup> Refer to [figure 5](#).

Set the Integral pole with S2 bank to:

Proportional = OFF

Time Constant = 0.47 seconds

Set the Differential pole with S3 bank to:

DIFF ON = ON

Time Constant = 0.1 seconds

Start with the PROPGAIN potentiometer all the way CCW and then slowly turn it CW until the temperature stabilizes. BE VERY CAUTIOUS WITH THIS STEP! The TOSA TEC is very responsive (capable of more than 50°C/s rate of change) and will take off quickly.

If the Temperature with the above TIME settings begins to run away, then quickly turn the "PROPGAIN" Potentiometer CCW until it stabilizes.

1)

Sub-mK stability requires a proper thermal design and proper tuning of the temperature controller to the thermal plant. If you did not purchase a D2-100 Diode Laser with your Laser Controller, please read the section on tuning the temperature controller.

2)

Libbrecht and Hall, A Low-Noise, High-Speed Current Controller, Rev. Sci. Inst. 64, pp. 2133-2135 (1993).

3)

Best noise performance obtained with Laser Controller powered by D2-005 placed 5 ft away from Laser Controller. Placing D2-005 closer to Laser Controller may increase 60 (50) Hz noise and harmonics. Specifications not guaranteed when Laser Controller is powered by device other than D2-005, or when placed near other noise sources.

4)

Laser module temperature changed while Laser Controller module held fixed.

5)

Laser module temperature fixed while Laser Controller temperature change.

6)

Temperature at which thermistor reads 10 kΩ

7) 8)

1mA resolution with D2-105-500

9)

Courtesy of [Photodigm](#)

From:

<https://www.vescent.com/manuals/> - **Product Manuals**

Permanent link:

[https://www.vescent.com/manuals/doku.php?id=d2:laser\\_controller](https://www.vescent.com/manuals/doku.php?id=d2:laser_controller)

Last update: **2019/03/19 18:01**

