

Reconfigurable Laser Servo



Vescent Photonics, Inc.
www.vescentphotonics.com
4865 E. 41st Ave
Denver, CO 80216
Phone: (303)-296-6766
Fax: (303)-296-6783

General Warnings and Cautions

The following general warnings and cautions are applicable to this instrument.

WARNING

This instrument is intended for use by qualified personnel who recognize shock hazards or laser hazards and are familiar with safety precautions required to avoid possible injury. Read the instruction manual thoroughly before using to become familiar with the instrument's operations and capabilities.

CAUTION

There are no serviceable parts inside the instrument. Work performed by persons not authorized by Vescent Photonics may void the warranty.

CAUTION

Although ESD protection is designed into the instrument, operation in a static-free work area is recommended.

WARNING

To avoid electrical shock hazard, connect the instrument to properly earth-grounded, 3-prong receptacles only. Failure to observe this precaution can result in severe injury or death.

WARNING

Do not clean outside surfaces of any Vescent Photonics products with solvents such as acetone. Front panels on electronics modules may be cleaned with a mild soap and water solution. Do not clean optics modules.

Limited Warranty

Vescent Photonics warrants this product to be free from defects in materials and workmanship for a period of one year from the date of shipment. If this product proves defective during the applicable warranty period, Vescent Photonics, at its option, either will repair the defective product without charge or will provide a replacement in exchange for the defective product. The customer must notify Vescent of the defective product within the warranty period and prior to product return. The customer will be responsible for packaging and shipping the defective product back to Vescent Photonics, with shipping charges prepaid.

Vescent Photonics shall not be obligated to furnish service under this warranty from damage caused by service or repair attempts made without authorization by Vescent Photonics; from damage caused by operation of equipment outside of its specified range as stated in either the product specification or operators manual; from damage due to improper connection to other equipment or power supplies.

This warranty is in lieu of all other warranties including any implied warranty concerning the suitability or fitness of the product for a particular use. Vescent Photonics shall only be liable for cost of repairs or replacement of the defective product within the warranty period. Vescent Photonics shall not be liable for any damages to persons or property resulting from the use of the product or caused by the defect or failure of this product. Vescent Photonics' liability is expressly limited to the warranty set out above. By accepting delivery of this product, the purchaser expressly agrees to the terms of this limited warranty.

Vescent Photonics

Printed Jul 29, 2011

Absolute Maximum Ratings

Note: All modules designed to be operated in laboratory environment

| Parameter | Rating |
|---------------------------|-----------------|
| Environmental Temperature | >15°C and <30°C |
| Environmental Humidity | <60% |
| Environmental Dew Point | <15°C |

1. Reconfigurable Laser Servo

Model No. D2-125

Document Revision: 2



1.1. Description

The D2-125 Reconfigurable Laser Servo contains a tunable PI²D loop filter for tight locking to an error signal. The error signal is either an amplified version of the Error Input signal (side-lock mode) or an amplified version of a demodulated Error Input (optional peak-lock mode). In both modes, a DC Offset is summed to the error signal, allowing the user to select the zero-crossing and thus the lock point. The error signal can also be inverted via a front-panel switch. Additionally, the Laser Servo has an internal ramp generator for sweeping the output, an optional temperature controller, and computer control functionality to make and break lock and directly control the output voltage.

The main component in the Reconfigurable Laser Servo is the PI²D loop filter, which means that the feedback has standard proportional (P), integral (I), and differential (D) feedback with a second integral feedback (I) providing the PI²D transfer function. The double integration is used to boost gain at low frequencies. With integrator frequencies tunable from 2 MHz down to 10 Hz, the Laser Servo can be optimized to a wide variety of plants and servo loops. With the Peak Lock option, the Laser Servo can demodulate a provided 4 MHz dither signal to enable slope-detection for locking to signal minimas and maximas. The Laser Servo can be used to lock a laser's current or PZT to an interferometer or an optical

transition. With peak-lock, the Laser Servo can perform Pound-Drever-Hall (PDH) locking to an optical cavity. The Reconfigurable Laser Servo uses basic voltage inputs and outputs. As a result, it can be used with lasers or with any voltage-tunable device with an error signal.

The Laser Servo can be unlocked by a computer (via TTL control) to jump the output voltage to a set voltage difference from the current lock point, or to a specific voltage. This feature can be used to jump the laser frequency a known distance away and then relock to the original or a new lock point frequency. This feature can be used for auto-locking or relocking routines.

The Laser Servo has an internal sweep generator to sweep the laser frequency prior to lock. It also optionally contains a temperature control circuit to maintain constant temperature for the Spectroscopy Module (D2-110) or other TEC-controlled environments.

1.1.1. Options

The D2-125 can be purchased with two options:

- **-PL – Peak Lock option**
- **-T – Temp stabilization option**

The Peak Lock option generates a 4 MHz dither signal that can be used to modulate the laser current. The amplitude and phase of this modulation can be adjusted via front panel controls. The Error Signal input will be demodulated relative to the dither signal which will generate a derivative of the input Error Signal. This derivative signal will be used to lock the laser to a minima or maxima of the input Error Signal. This is often referred to as peak-locking. If purchased with the Peak Lock option, the Laser Servo can still be used in side-lock mode. A front panel switch controls whether the D2-125-PL is in side-lock or peak-lock mode. When in side-lock mode the modulation / demodulation circuitry is disabled. **In this manual, sections that are only relevant to the Peak Lock option are printed in red.**

The Temp option is designed for use with the Vescent Spectroscopy Module (D2-110). It provides power ($\pm 12V$) to the photo-detector board and stabilizes the module's temperature via the TEC's and a thermistor in the D2-110 module. **In this manual, sections that are only relevant to the Temp stabilization Lock option are printed in blue.**

When the D2-125 is purchased as one component in a complete laser system, the integrator and differential poles are factory-tuned to the optimal values for locking the laser to an error signal from a spectroscopic signal from a D2-110. In this configuration, the primary servo output is designed to control the injection current in the laser and should be connected to the D2-105 Current Servo Input. The auxiliary servo output can be used to control the temperature of the D2-100 DBR laser. The auxiliary servo output will slowly steer the temperature of the laser such that the injection current remains near the center of the servo range. This function is useful when maintaining frequency locks for long times (days). To use this function, connect the auxiliary output to the D2-105 Temp Servo Input.

The D2-125 can be used to servo nearly any voltage-tunable device. For example, a common application for this servo is with an external-cavity diode laser. In this case, the primary output of the servo controls the injection current in the laser diode. The auxiliary output of the servo controls a PZT. If used in this configuration, the auxiliary output can be configured to have either the same or the opposite gain sign as the primary output. In case the PZT is sensitive to negative voltages, the auxiliary output can be configured to provide a unipolar positive voltage output. The internal ramp can be applied to either the primary servo output or the auxiliary servo output. These functions are further described in section 10.

1.2. Specifications

| | Value | Units |
|---|---|------------------------|
| Input and Output Impedance | 50 | Ω |
| Output Voltage | ± 10 | V |
| Input Voltage Noise¹ | <5 | nV/ $\sqrt{\text{Hz}}$ |
| Max Input Voltage DC Level¹ | ± 500 | mV |
| Max Input Voltage Signal Amplitude¹ | ± 500 | mV |
| Bandwidth² | >10 | MHz |
| Proportional Gain (ref to Input Error) Proportional Gain (ref to DC Error) | -40 to +32 -66 to +6 | dB |
| First Integrator | Off, 10 Hz, 20 Hz, 50 Hz, 100 Hz, 200 Hz, 500 Hz, 1 kHz, 2 kHz, 5 kHz, 10 kHz, 20 kHz, 50 kHz, 100 kHz, 200 kHz | |
| Second Integrator | Off, 100 Hz, 200 Hz, 500 Hz, 1 kHz, 2 kHz, 5 kHz, 10 kHz, 20 kHz, 50 kHz, 100 kHz, 200 kHz, 500 kHz, 1 MHz, 2 MHz | |
| Differential | Off, 500 Hz, 1 kHz, 2 kHz, 5 kHz, 10 kHz, 20 kHz, 50 kHz, 100 kHz, 200 kHz, 500 kHz, 1 MHz, 2 MHz, 5 MHz, 10 MHz | |
| Differential Gain | 5 to 15 | dB |
| Auxiliary Servo Output Gain | Integral: 60 msec to 6 sec | |
| Laser Freq. Jump | | |
| Input Impedance | 10 | k Ω |
| Jump Time | <400 | μs |
| Ramp Amplitude (Max) | ± 5 | V |
| Ramp Frequency | 500 | Hz |
| Dither Frequency (-PL only) | 4 | MHz |
| RF Output Max Amplitude (-PL only)³ | 60 | mV |

¹ Referenced to 50 Ω load input

² Oscillation frequency when Laser Servo locked to itself in proportional mode.

³ Driving 50 Ω load

1.3. Inputs, Outputs, and Controls

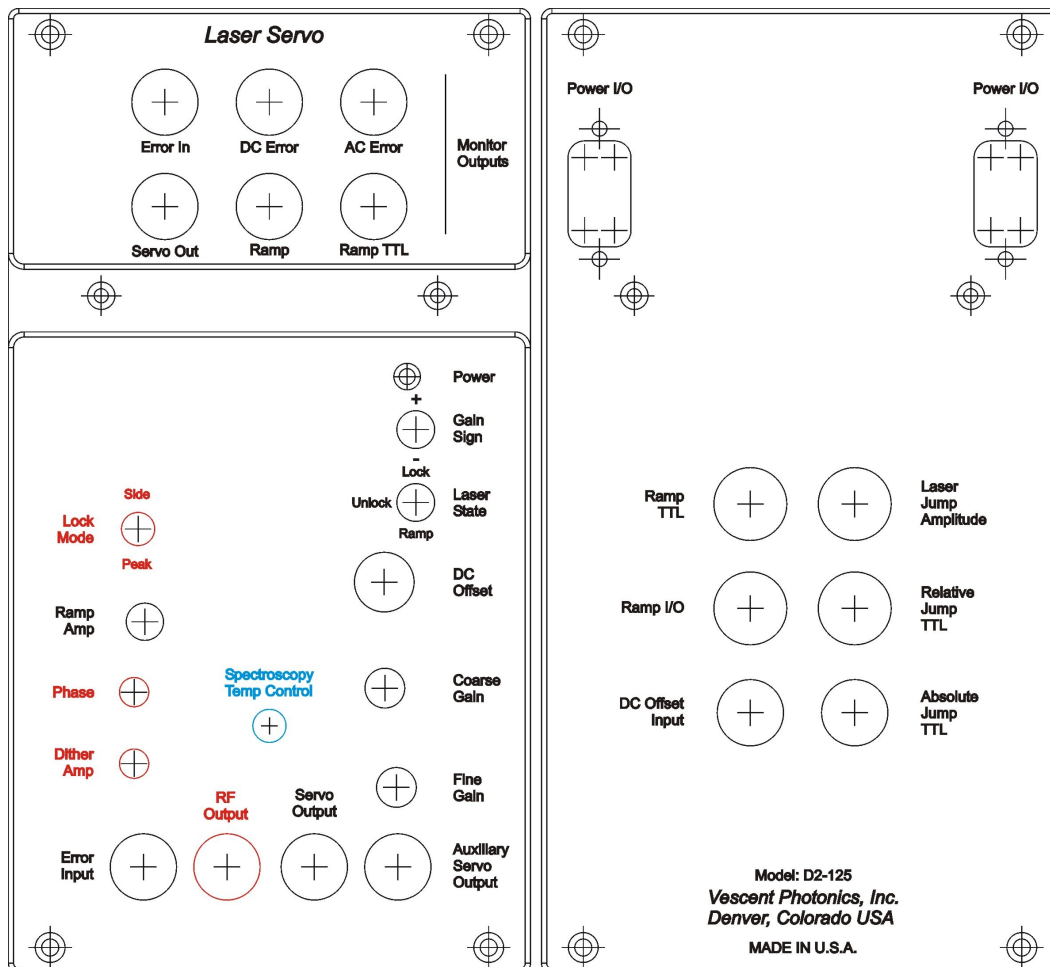

Figure 1: Schematic drawing of the front and back panels.

1.3.1. Monitor Section

Located at the top of the front panel, the monitor section contains 6 BNC outputs for monitoring various signals used by the Laser Servo.

Error In

In SIDE LOCK mode, the ERROR IN monitor is a buffered and filtered version of the ERROR INPUT. In PEAK LOCK mode, the ERROR IN monitor is a buffered and filtered version of the demodulated signal from ERROR IN. In both modes, the monitor has a 300 kHz low-pass filter.

DC Error

The signal from ERROR IN (after demodulation if in PEAK LOCK mode) is amplified by 26 dB (x20). The amplified signal is summed with both the DC OFFSET as set on the front panel and the back-panel DC OFFSET INPUT. The DC ERROR is passed through a low pass filter with a roll off of 200 kHz, so that high frequency noise does not obfuscate the signal. The DC level of

the DC ERROR sets the lock-point and can be adjusted with the DC OFFSET knob. When locked, the Laser Servo acts to drive the DC ERROR to zero.

AC Error

The AC ERROR monitors the same signal as the DC ERROR, except there is no low-pass filter and the signal is coupled through a high pass filter to remove DC components (< 10 Hz). It is designed for spectrum analysis and is also useful for coarse estimates of the laser line-width. The bandwidth of the AC ERROR is limited by the preceding amplifier stages to greater than 20 MHz.

Servo Out

The SERVO OUT monitors the correction signal that is fed back to the laser, SERVO OUTPUT. The signal is the output from the tunable loop filter.

Ramp Mon

The RAMP MON is a monitor for the actual ramp signal sent to the SERVO OUTPUT when the laser is in RAMP mode.

Ramp TTL

The RAMP TTL is a trigger synchronous with the ramp. It is usually used to trigger an oscilloscope while sweeping the SERVO OUTPUT. The RAMP TTL signal is also available on the back panel as a dedicated trigger output.

1.3.2. Front Panel

Power (LED indicator)

All electronic modules have a blue LED power indicator on the top right side of the front panel control section. The LED requires +15V and -15V in order to light.

Lock Mode (two-position switch) –PL only

When set to the PEAK LOCK position, this switch routes the ERROR IN to a FM demodulation circuit that extracts the error signal, which is then passed to the Loop Filter circuit. In the SIDE LOCK position, the demodulation circuit is bypassed and the signal is fed directly to the Loop Filter circuit. Additionally, the RF OUTPUT is disabled in SIDE LOCK.

Ramp Amp (1-turn knob)

The RAMP AMP sets the amplitude of the internal ramp generator.

Phase (25-turn trimpot) –PL only

When purchased as part of a complete laser system, the PHASE control is set at the factory and generally will not require further adjustment. The PHASE control adjusts the phase between the dither signal at RF OUTPUT and the local oscillator used to demodulate the signal coming in to ERROR INPUT. It is used to maximize the demodulated DC ERROR signal while the laser is sweeping across the desired transition(s) or lock points. The dither frequency is 4 MHz.

Dither Amp (25-turn trimpot) –PL only

The DITHER AMP control is used to set the amplitude of the dither signal at RF OUTPUT. When purchased as part of a complete laser system, it is set at the factory and generally will not

require further adjustment. When used with the D2-105 Laser Controller, the RF OUTPUT should be connected to the Laser Controller's RF INPUT to modulate the laser current.

Error Input (BNC)

This is the input for the error signal. In SIDE LOCK mode, the signal is amplified by 26 dB and summed with the DC OFFSET and DC OFFSET INPUT (back panel). In PEAK LOCK mode, the ERROR INPUT is demodulated by the dither frequency and is then amplified by 26 dB and summed with the DC OFFSET and DC OFFSET INPUT (back panel). In both modes the amplified signal can be seen with the DC ERROR MONITOR and the AC ERROR MONITOR.

RF Output (BNC) –PL only

The RF OUTPUT signal is the 4 MHz dither or FM modulation signal. When used with the D2-105 Laser Controller, it should be connected to the RF INPUT on the Laser Controller. In SIDE LOCK mode the dither to the RF OUTPUT is turned off.

Gain Sign (two-position switch)

The GAIN SIGN reverses the sign of the signal input from ERROR INPUT and should be used if the desired lock-point has the wrong slope (loop is providing positive feedback instead of negative feedback). Switching GAIN SIGN will invert the pattern seen at DC ERROR. When triggering an O-scope with the RAMP TTL signal on a positive edge, the Laser Servo locks to a zero crossing with a positive slope.

Laser State (three-position switch)

The lock switch has three positions. The lowest is the RAMP, which connects the internal ramp to the SERVO OUTPUT causing the laser to sweep. The amplitude of the sweep is controlled with RAMP AMP knob. In the center position (UNLOCK) the ramp is disconnected and zero volts is output to SERVO OUTPUT. In the top position (LOCK) the loop filter is engaged.

DC Offset (10-turn potentiometer)

The DC OFFSET knob adds a DC offset to the DC ERROR MONITOR signal. Since the servo locks to the point where the DC ERROR MONITOR reads 0V, adjusting the DC OFFSET changes the lock point.

Coarse Gain (seven-position switch)

The COARSE GAIN sets the overall proportional gain of the circuit without changing the location of any zeros or poles in the loop filter transfer function. Relative to the DC ERROR MONITOR, the Coarse Gain adjusts the gain from 0dB to -60dB.

The overall loop gain (controlled by both the COARSE GAIN and the FINE GAIN) should be set around the point that minimizes the RMS noise on the DC ERROR MONITOR. This can sometimes result in setting the gain too high because the DC ERROR MONITOR filters high frequencies and thus hides some of the gain peaking with high gain. To precisely set the gain, look at the noise with a spectrum analyzer through the AC ERROR MONITOR.

Fine Gain (1-turn knob)

The FINE GAIN control adjusts the proportional gain by +6 to -6 dB.

Servo Output

The SERVO OUTPUT is a voltage output to control the frequency of the laser. When the Laser Servo is used with the D2-105 Laser Controller, the SERVO OUTPUT is connected to the CURRENT SERVO INPUT on the Laser Controller. The SERVO OUTPUT is the output from the loop filter when in LOCK mode, zero volts when in UNLOCK mode, and a DC balanced triangle wave when in RAMP mode.

Auxiliary Servo Output

The AUXILIARY SERVO OUTPUT is generated from integrating the SERVO OUTPUT. Its purpose is to supply a correction signal to drive the SERVO OUTPUT to zero. When used with Vescent DBR lasers and the D2-105 Laser Controller, the AUXILIARY SERVO OUTPUT can be connected to the TEMP SERVO IN to adjust the laser diode temperature to keep the feedback laser current constant. Similarly, AUXILIARY SERVO OUTPUT can drive a PZT on an external-cavity laser diode to keep the laser diode current constant. See AUXILIARY SERVO: GAIN SIGN and AUXILIARY SERVO: GAIN in section 1.3.3 for information on setting the gain and gain sign of the AUXILIARY SERVO OUTPUT.

Spectroscopy Temp Control –T only

This is an 8-pin connector (HR25-7TR-8SA) that connects to the Spectroscopy Module, D2-110. The connector provides power to the Spectroscopy Module's photo-detector and connects the Module's thermistor and TEC to the Laser Servo's temperature controller. The pin definitions are listed below where Rth and Rth_Rtn are the two ends of the thermistor.

| Pin | Signal |
|-----|---------|
| 1 | TEC+ |
| 2 | TEC- |
| 3 | +15 V |
| 4 | Rth_Rtn |
| 5 | Rth |
| 6 | -15 V |
| 7 | NC |
| 8 | GND |

1.3.3. Right Side Panel

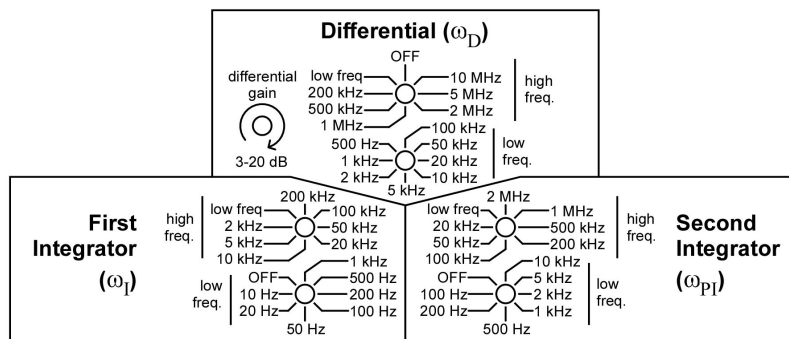
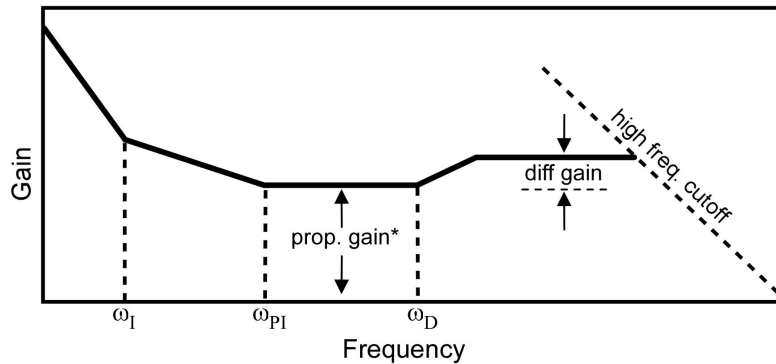
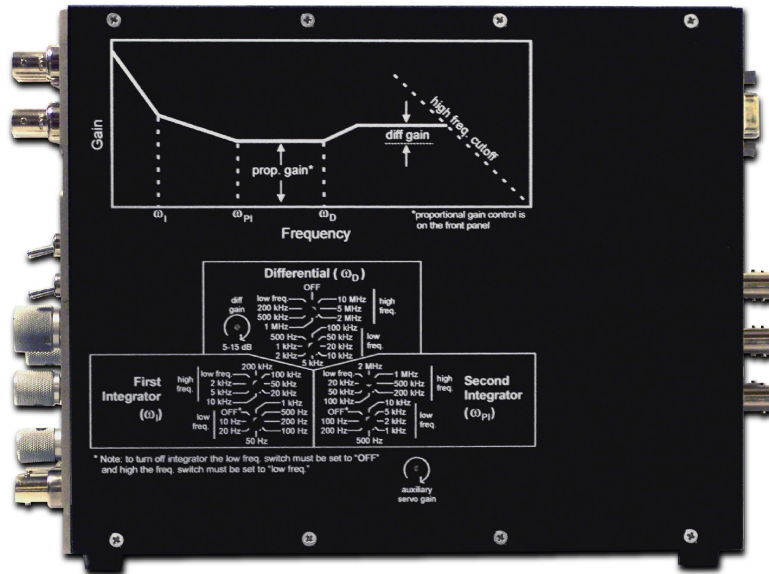

*proportional gain control is on the front panel



Figure 2: TOP: Picture of right-side panel. BOTTOM: schematic of the configurable transfer function and its user-controls.

The feedback loop is defined by the Gain vs Frequency plot shown above. ω_I , ω_{PI} and ω_D define three zeros in the transfer function. ω_I and ω_{PI} are the frequencies where the first and second integrators respectively switch from having integral gain to having proportional gain. ω_D is the frequency where the gain switches from proportional to differential. ω_I , ω_{PI} and ω_D are controlled by two rotary switches, where the upper switch is used to select higher frequencies, and the lower switch is used for selecting the lower frequencies. The upper switch must be in the “low freq” position to engage the lower switch.

NOTE: Adjusting the loop filter poles and zeros while locked may result in loss of lock. If this happens, unlock laser before adjusting poles and zeros and relock laser after adjustment.

First Integrator (TOP)

Sets the frequency of the first integrator (ω_I). This knob only selects higher-frequency positions (2 kHz – 200 kHz). To set ω_I to lower frequencies, this knob must be placed in the LOW FREQ position.

First Integrator (BOTTOM)

Sets the frequency of the first integrator (ω_I). This knob only selects the lower-frequency positions (10 Hz – 1 kHz) and is only active if the FIRST INTEGRATOR (TOP) knob is in the LOW FREQ position. To turn off the integrator, this knob must be placed in the OFF position *and* the FIRST INTEGRATOR (TOP) knob must be in the LOW FREQ position.

Second Integrator (TOP)

Sets the frequency of the second integrator (ω_{PI}). This knob only selects the higher-frequency positions (20 kHz – 2 MHz). To set ω_{PI} to lower frequencies, this knob must be placed in the LOW FREQ position.

First Integrator (BOTTOM)

Sets the frequency of the second integrator (ω_{PI}). This knob only selects the lower-frequency positions (100 Hz – 10 kHz) and is only active if the SECOND INTEGRATOR (TOP) knob is in the LOW FREQ position. To turn off the integrator, this knob must be placed in the OFF position *and* the FIRST INTEGRATOR (TOP) knob must be in the LOW FREQ position.

Differential (TOP)

Sets the frequency of the differentiator (ω_D). This knob only selects the higher-frequency positions (200 kHz – 10 MHz) and can turn off the differential by placing the switch in the OFF position. To set ω_D to lower frequencies, this knob must be placed in the LOW FREQ position.

Differential (BOTTOM)

Sets the frequency of the differentiator (ω_D). This knob only selects the lower-frequency positions (500 Hz – 100 kHz) and is only active if the DIFFERENTIAL (TOP) knob is in the LOW FREQ position.

Differential Gain (25-turn trimpot)

Sets the maximum differential gain. 25-turn trimpot adjusts the gain from 5dB to 15dB.

Auxiliary Servo: Gain (25-turn trimpot)

This trimpot sets the gain for the AUXILIARY SERVO OUTPUT.

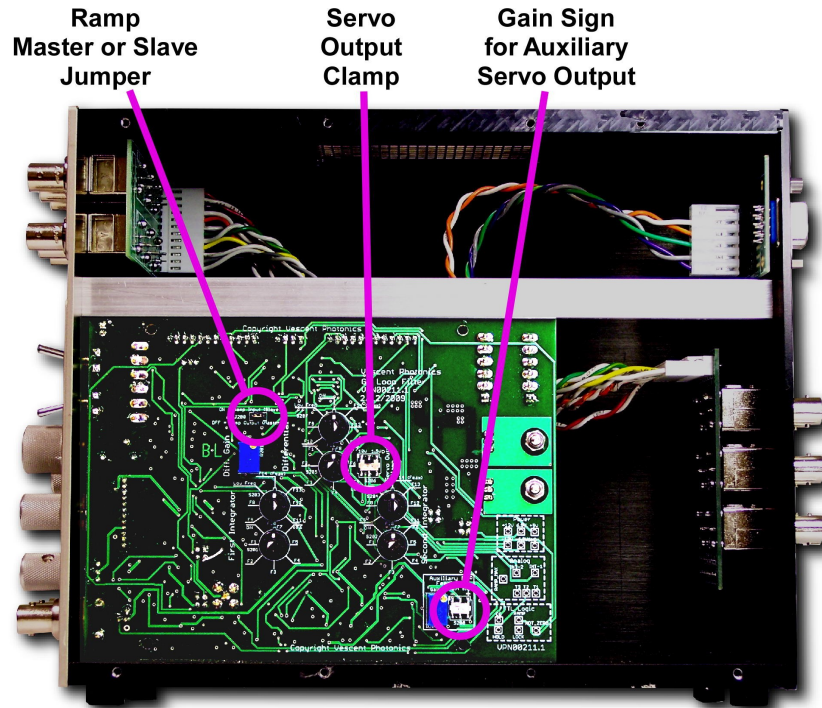

Figure 3: There are six controls which will rarely need adjustment and these controls are only accessible by removing the right-side panel, as shown in the figure above.

Auxiliary Servo: Gain Sign (2-position switch)

This switch is only accessible by removing the right side panel (see above). This switch sets the gain sign for the AUXILIARY SERVO OUTPUT.

Ramp Master / Slave (Jumper)

This jumper is only accessible by removing the right side panel (see above) and sets whether the ramp input is in master or slave mode. It is factory set to be in MASTER MODE. In SLAVE MODE (jumper off) the RAMP signal is generated externally and input through the back panel RAMP I/O port. In MASTER MODE (jumper on) the ramp is generated internally and is sent out to the RAMP I/O port for driving other D2-125 Laser Servos configured in SLAVE MODE.

Note: In some versions of the board, the text above this jumper is mislabeled. Regardless of the text, when the jumper is on, the ramp is configured as the master; when the jumper is off the ramp is configured as a slave.

Ramp Servo Out/Auxiliary (2-position slider switch)

This 2-position slider switch is only accessible by removing the right side panel (see above) and sets whether the ramp is applied to the servo output or the auxiliary output. It is factory set so the

ramp is applied to the servo output. When switched to the other position, the ramp is applied to the auxiliary output.

Auxiliary unipolar/bipolar (2-position slider switch)

This 2-position slider switch is only accessible by removing the right side panel (see above) and sets whether the auxiliary output is unipolar or bipolar. It is factory set to be bipolar so the auxiliary output can range from -12 V to +12 V. For some applications such as driving a PZT, limiting the voltage range to positive values is necessary. When this switch is in the unipolar mode, the auxiliary output ranges from -0.5 V to +12 V.

Power I/O (9-pin D-sub)

The power to each electronics module is through a 9-pin D-sub connector through either a power bridge unit or a serial cable with 9-pin D-sub connectors, which is convenient when the unit must be taken out of line for access to the side panels. The pin outs are shown in the following figure:

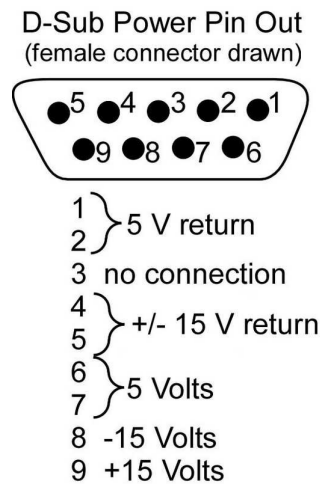

Absolute Jump TTL (BNC)

When asserted HIGH (5V) while in LOCK mode, ABSOLUTE JUMP takes the Laser Servo out of lock and conveys the voltage on LASER JUMP AMPLITUDE to the SERVO OUTPUT. Thus, a 1 V input to LASER JUMP AMPLITUDE applies 1 V to SERVO OUTPUT. ABSOLUTE JUMP is useful when one wants to control the voltage on the integration stages of the loop filter, or for zeroing the integrators during auto-locking routines. When returned to LOW (0V), the loop filter is reengaged. Engaging or disengaging the ABSOLULTE JUMP is achieved in under 400 μ s.

When asserted HIGH (5V) while in RAMP mode, ABSOLULTE JUMP applies a DC offset equal to the LASER JUMP AMPLITUDE to the ramp signal at SERVO OUTPUT. When asserted LOW while in RAMP mode, the ramp signal is DC balanced.

When disconnected, ABSOLULTE JUMP is low.

Relative Jump TTL (BNC)

When asserted HIGH (5V) while in LOCK mode, RELATIVE JUMP engages a sample-and-hold circuit and takes the Laser Servo out of lock. The voltage on the SERVO OUTPUT is the sample-and-hold value summed in with the LASER JUMP AMPLITUDE. For example, if the laser is

locked and the SERVO OUTPUT is -200 mV, then engaging the RELATIVE JUMP and putting 300 mV on the LASER JUMP AMPLITUDE will make the SERVO OUTPUT 100mV (-200 mV + 300 mV). This feature is useful for jumping the laser relative to its current lock point (say +200 MHz from a locked transition). When returned to LOW (0V), the loop filter is reengaged, enabling the laser to be relocked to its original position (by setting LASER JUMP AMP to zero), or to a new lock point. Engaging or disengaging the RELATIVE JUMP is achieved in under 400 μ s.

When asserted HIGH (5V) while in RAMP mode, RELATIVE JUMP applies a DC offset equal to the LASER JUMP AMPLITUDE to the ramp signal at SERVO OUTPUT. When asserted LOW (0V) while in RAMP mode, the ramp signal is DC balanced.

When disconnected, RELATIVE JUMP is low.

Ramp TTL

Same as the front panel signal. The RAMP TTL is a trigger synchronous with the ramp. It is used to trigger an oscilloscope while sweeping the SERVO OUTPUT.

Ramp IN / OUT

The Laser Servo is shipped with the Ramp in MASTER MODE. In this configuration, the RAMP IN / OUT is an output of the maximum ramp signal, generated internally. Removing the side-panel RAMP MASTER / SLAVE jumper will put the Laser Servo in slave mode. In this configuration, RAMP IN / OUT is an input of an external ramp signal. When the LASER STATE is in RAMP MODE, the SERVO OUTPUT is an attenuated version of the input to RAMP IN / OUT. The attenuation is controlled by the RAMP AMP knob. If controlling multiple lasers with multiple D2-125's so sync the ramps, one D2-125 must be in master mode and the rest in slave mode with all the RAMP IN / OUT signals connected. In this way each laser will sweep off a synced signal and only one oscilloscope trigger is needed for all the lasers.

DC Offset Input

This signal is attenuated by a factor of 10 and summed into the DC ERROR. Inputting a square wave into the DC OFFSET INPUT jumps the laser lock point and can be used to measure the closed-loop transfer function of the laser system.

Laser Jump Amp (BNC)

The LASER JUMP AMPLITUDE is an analog signal that is used to jump the frequency of the diode laser. See preceding sections on RELATIVE JUMP and ABSOLUTE JUMP for a full explanation.

1.4. Laser Lock Troubleshooting

Most laser locking problems can be attributed to the following:

- **Gain set too high (or too low).** Reduce the coarse and fine gain all the way and try locking. Increase the coarse gain by one click at a time.
- **Gain sign wrong** (trying to lock to the wrong slope).

- Make sure the oscilloscope is triggering to positive slope⁴.
- Make sure oscilloscope is not in inverting mode.
- Make sure your desired lock-point has a positive slope.
- If all else fails, flip the gain sign and try again.

Note: sometimes the laser will lock even if the slope is wrong because there are legitimate lock-points nearby. This can fool you into thinking you are locking to the proper spot.

- **DC OFFSET not adjusted properly.**
 - When monitoring DC ERROR make sure you are not AC coupled on the oscilloscope!
 - When locking to spectroscopy, ramping fast through the transition can change the DC value on the scope (due to atom transit time through laser beam coupling to optical pumping rates). Reduce RAMP AMP towards zero on the desired transition until the DC value is not affected. Adjust DC OFFSET if necessary.
- **Loop Filter Too Fast.** Try turning off the differential feedback and only use one integrator. Then try slowing down your integrator. If you get a lock, you can then put back double integration and the differential feedback.
- **The ramp center is not located at the center of the oscilloscope.** When adjusting the RAMP AMP, the oscilloscope signal will expand and contract about a single point. That “breathing point” should be centered in the middle of the oscilloscope and can be adjusted by changing the trigger delay of the oscilloscope. When set properly, if the oscilloscope is centered exactly on an atomic transition or other feature, then that feature will remain centered on the oscilloscope even when the RAMP AMP is turned all the way up or down.
- **Magnetic fields are interfering with the spectroscopy signal.** If the servo is used with a spectroscopy module (D2-110), magnetic fields can make locking difficult. When locking to spectroscopy, even though the spectrum might look okay, strong magnetic fields can affect the effective transfer function of the spectroscopy error signal in a negative way, making locking difficult. If using the D2-110 Spectroscopy Module and a D2-100 laser, make sure the laser module is at least three inches away from the spectroscopy module. In some cases, strong magnetic fields can emanate from the optics table (if magnetic clamps are in use).

If you are having problems locking the laser, it is a good idea to not use the AUXILIARY SERVO OUTPUT as this complicates the system. Once you get the locking to work properly, you can reconnect this cable.

⁴ It is not necessary to trigger the oscilloscope to a positive slope, however, switching the trigger slope will change whether the servo locks to a positive slope (positive slope trigger on oscilloscope) or negative slope (negative slope trigger on oscilloscope)